

## Balance Bars

### HOW IT WORKS

The balance bar takes the force you apply to the pedal and distributes it to the front and rear master cylinders. The percentage of force that goes to each master cylinder depends on the balance bar adjustment position. If the center spherical joint (located in the tube) is positioned exactly in the center of the two master cylinder pushrod clevises, then each master cylinder sees the same amount of pushrod force. Rotating the threaded adjusting shaft moves the spherical joint relative to the two clevises. For example, if you turn the shaft and the spherical joint moves closer to the left clevis, then the left clevis will see more of the force from the pedal than the right clevis.

A common misconception is that changing the length of the master cylinder pushrod will alter how much force each master cylinder sees, or that it will decide which master cylinder builds pressure first. This is not true. Both master cylinders will start to build pressure at the same time and the balance bar adjustment position will decide how much force is distributed to each master cylinder.

There are three areas of which you must pay particular attention in the installation of the balance bar. First, the assembly must not bind-up or bottom-out in any manner. Its ability to pivot freely is what allows it to function. Secondly, we are concerned with the balance bar's position with the pedal depressed every bit as much as we are with the pedal in its relaxed position. **Diagram B** shows the correct setup with the pedal depressed and **Diagram C** shows the wrong setup with the pedal depressed. Third, make sure there is enough firewall clearance to allow at least 1" of stroke for all master cylinders.

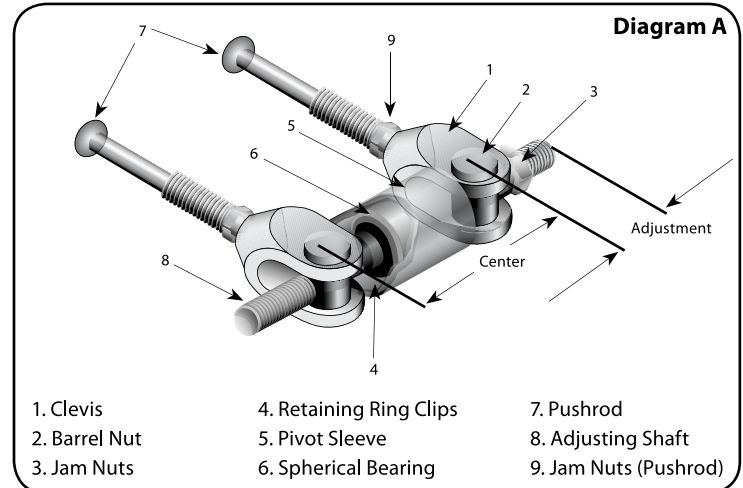

### B. INSTALLATION

#### (Proceed to Step #6 if you are not fabricating a pedal)

1. Drill a hole in the existing pedal to the diameter listed in **Chart 1**, based on Pivot Sleeve diameter (Item 5 in **Diagram A**) and balance bar part number. This should be in-line with the horizontal centerline of the existing master cylinder. Master cylinder center-to-center distance should not vary more than .100" from the balance bar's center-to-center distance, as this would result in premature master cylinder failure.
2. Before welding the pivot sleeve, remove the pivot sleeve from the balance bar assembly.
3. Position the pivot sleeve in the pedal and weld into place.
4. After welding is complete, slide the adjusting shaft (Item 8 in **Diagram A**) through the pivot sleeve and make sure that the spherical bearing slides freely from side-to-side without binding in the pivot sleeve.
5. If the bearing binds in the sleeve, the sleeve may have shrunk or gone out of round during the welding process. If so, bore the pivot sleeve to **1.007"** (P/N 72-250) **or 1.002"** (P/N 72-260).
6. Remove one clevis/barrel nut, then insert the adjusting shaft through the pivot sleeve towards the outside of the pedal.

**Chart 1**

Part Number	Threaded Diameter	Clevis-to-Clevis Center Distance	Drill Diameter
72-250	3/8"	2.50"	1 3/16"
72-260	7/16"	2.63"	1 3/16"

7. Screw the clevis/barrel nut back onto the adjusting shaft with the flat counter-bore of the barrel nut facing outward. Screw the jam nut onto the adjusting shaft with the shaft of the jam nut toward the barrel nut. The jam nut shaft must seat between the two sides of the clevis and fit into the flat counter-bore of the barrel nut.

**Note:** A jam nut is not required when a Remote Brake Bias Adjuster is used.

### C. ADJUSTMENT AND OPERATION

When running on pavement, you want the front tires to lock-up with slightly less pedal pressure than the rears. This will help to keep the car stable and prevent it from going into a spin.

- Loosen both of the jam nuts on the adjusting shaft (Item 3 in **Diagram A**).
- Turn the adjusting shaft (Item 8 in **Diagram A**) so that it advances the spherical bearing closer to the selected master cylinder, increasing the braking force produced by that master cylinder (**Chart 2**). The balance bar must be adjusted with the pedal in the relaxed position (**Diagram D**).
- The balance bar has a large adjustment range. However, if you find that what you need is outside of the adjustment range, you will need to make a master cylinder bore size change. There are three possible changes that can be made (See below). All changes will allow the spherical joint to move back towards the center position.
  - Decrease the bore size of the master cylinder closest to the spherical joint by 1/8". This will decrease the amount of pedal force required from the foot and increase the amount of pedal travel.
  - Increase the bore size of the master cylinder farthest from the spherical joint by 1/8". This will increase the amount of pedal force required by the foot and decrease the amount of pedal travel.
  - Increase the bore size of the master cylinder farthest from the spherical joint by 1/16". Decrease the other master cylinder bore size by 1/16". This will maintain the amount of force or pedal travel.
- When satisfied with the adjustment bar location and force distribution, tighten the jam nut (Item 3 in **Diagram A**). *A jam nut is not required when a Remote Brake Bias Adjuster is used.*

**Chart 2**

<b>Force Distribution (2.5" Clevis Center-to-Center)</b>		
<b>Spherical Joint Position</b>	<b>Left Clevis</b>	<b>Right Clevis</b>
3/8" left-of-center	65%	35%
1/4" left-of-center	60%	40%
1/8" left-of-center	55%	45%
Centered	50%	50%
1/8" right-of-center	45%	55%
1/4" right-of-center	40%	60%
3/8" right-of-center	35%	65%

**Diagram B**  
Pedal Depressed  
(Correct)

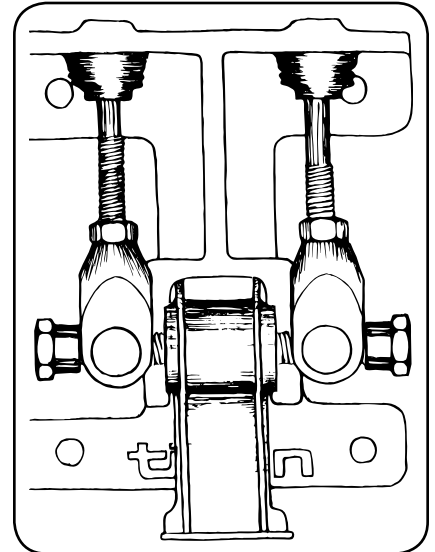

**Diagram C**  
Pedal Depressed  
(Incorrect)

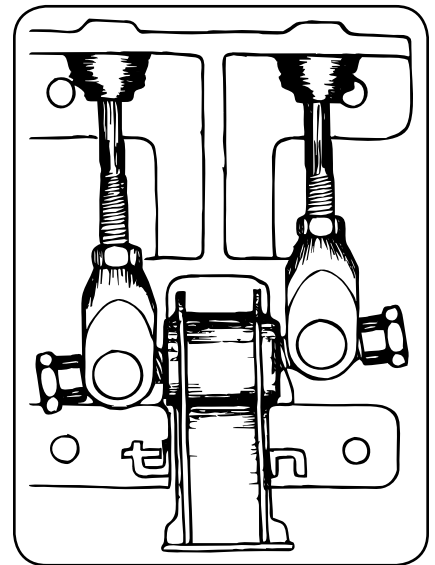

**Diagram D**  
Pedal Relaxed  
(Correct)

